



*Jack Rettig*

## SAE Aero Design Regular Class

Nour Amous, Paskah Deo Gratas, Alex Dixon, Joshua de Boisblanc, Charles Hamilton, James Szeszycki

HALLIBURTON



ExxonMobil

### Objective

To designed and built an aircraft that can carry 35 passengers and 17.5 lbs. of luggage while observing a maximum power constraint to compete in the SAE Aero West Competition.

$$Final\ Flight\ Score\ (FFS) = \frac{1}{40N} \left[ \sum_1^N \$100P + \$50C - \$100E \right]$$

*N* = Total number of flight rounds during competition  
*P* = Number of seated passengers carried on a flight  
*C* = Luggage weight [lb]  
*E* = Number of empty seats

### Engineering Specifications

Component	Specification	Result
Wingspan	< 144 in	143.5 in
Gross Aircraft Weight	< 55 lb	30 lb
Empty Weight	15 lb	18 lb
Passengers	35	20
Luggage	17.5 lb	10 lb
Motor Power Limit	1000 W	-

### Electronics

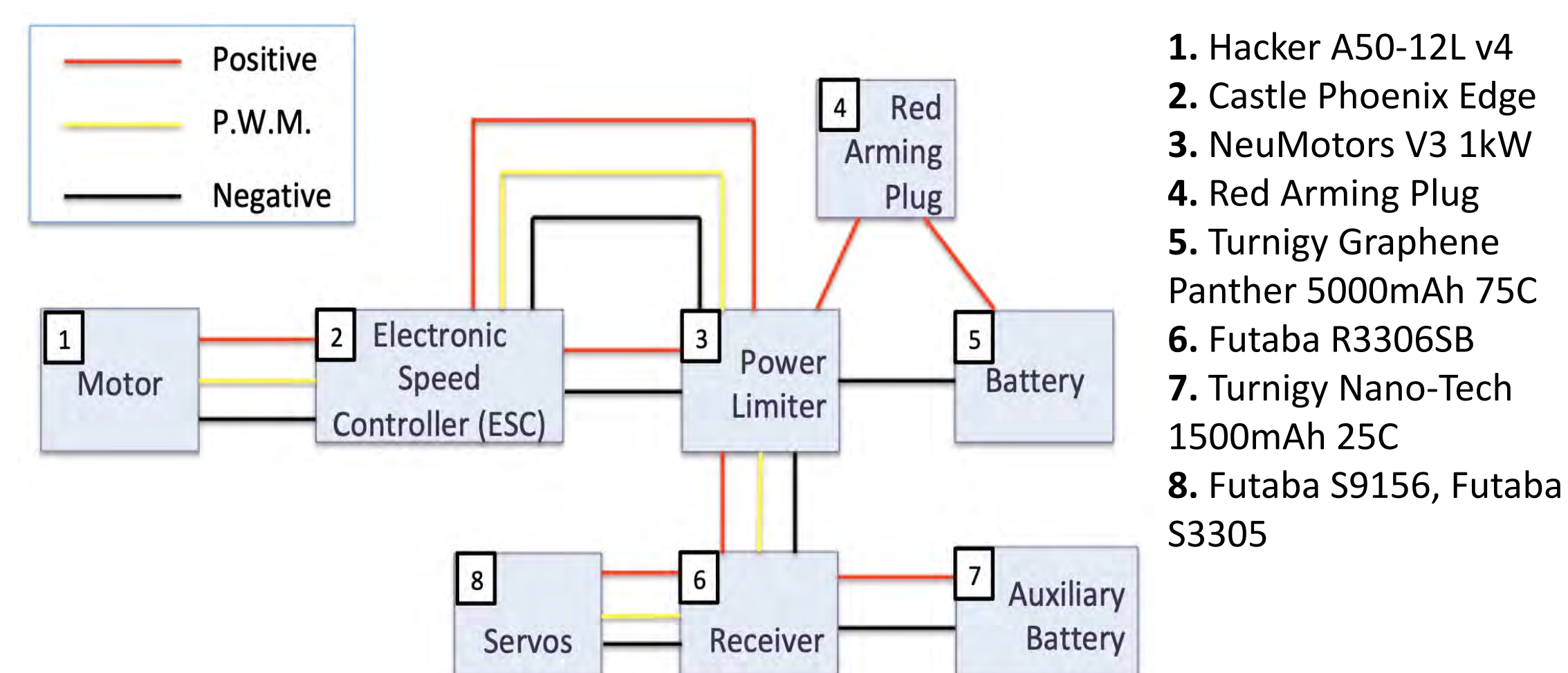

### Analysis

Component	Result
Ground Run Analysis	160 ft
Airfoil Determination	CH 10-48-13
Takeoff Velocity	24.2 $\frac{ft}{s}$
Rate of Climb	2.9 $\frac{ft}{s}$
Wing Area Determination	20.9 $ft^2$
Static Thrust	11.3 lb

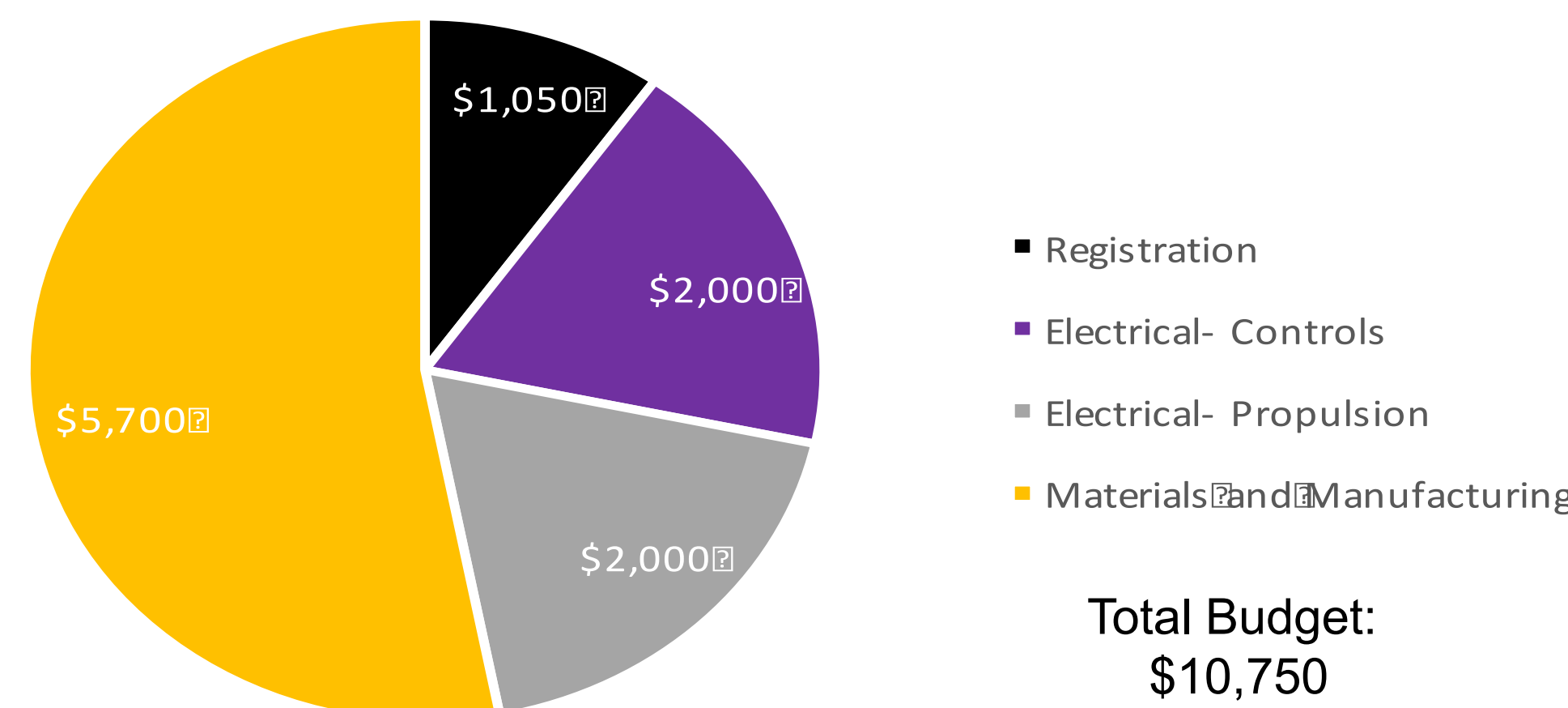

### Safety

- Proper PPE
- Red arming plug
- Motor safety nut
- Propeller awareness
- Lipo-safe charging bags
- Fail-Safe System

### Manufacturing

Component	Material	Process
Wings and Tail	EPS Foam, Balsa Sheet	Hot wire shaping and wrapped in Balsa
Fuselage	Balsa Wood, Spruce	Laser cut, glued with CA and Epoxy
Landing Gear	3/16" thick Aluminum 6061 plate	Cut a strip for each leg, bent, attached axils. Nose is commercially available product.

### Testing

Component	Objective
Motor/Propeller	Static and dynamic thrust testing
Fuselage	Drop test
Wings	Wing bending
Landing Gear	Drop test
Flight	Takeoff distance, stability, controllable landing

### Results

Component	Score	Rank
Report	35.4388	15th
Presentation	42.4167	6th
Flight	0	13th

29<sup>th</sup> Overall of 37

